

# Universal Machine UM/SK 80

- Mixing
- Cooling
- Dispersing
- Size Reduction
- Emulsifying
- Heating
- Deaerating (Vacuum)
- Cooking under vacuum / under pressure



## Typical Applications:

- Processed Cheese
- All kinds of fresh cheese preparations
- Dressings, sauces
- Baby food
- Confectionery fillings
- Butter preparations
- Almond paste, marzipan
- Mayonnaise, ketchup

## Advantages:

- Short batch times
- Configurable for many different applications
- Complete product emptying (minimal losses)
- Energy efficient
- Very few manual operating procedures
- Easy to integrate in a production line
- Production data can be easily transferred to external systems
- Traceability of historical production data
- PLC controlled process sequences

## Options:

- Vacuum condenser for cooling and dehumidifying
- Charging device
- Discharge pump
- Discharge tank
- Frequency controlled main drive

**Dimensions UM/SK 80:**

overall height with lid open: 2000 mm

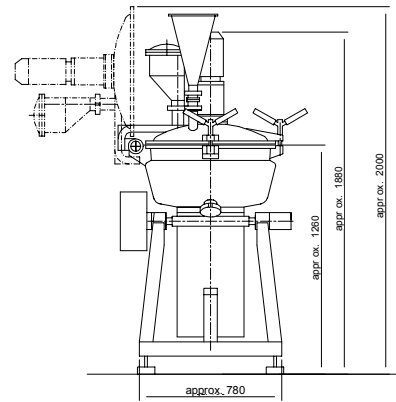
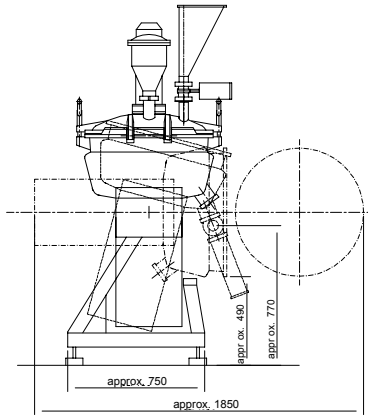

**Machine Data:**

Bowl content	(l) app.	80
Batch quantity (product-dependant)	(l) max.	70
Net weight of machine	kg	800
Max. vacuum in the bowl	bar (PSI)	-1.0 (-14.22)
Max. over pressure in the bowl	bar (PSI)	8.0 (11.6)
Max. operating temperature in the bowl	°C (°F)	125 (257)
Max. operating pressure in the double jacket	bar (PSI)	2.0 (28.44)
Max. operating temperature in the double jacket	°C (°F)	133 (271)
Min./ Max. compressed air	bar (PSI)	6-8 (85-114)
<b>Guide values for the steam connection</b>		
Steam supply	kg/h	250
Steam feeding-pressure	bar (PSI)	6-8 (85-114)
Steam pressure at the machine	bar (PSI)	2-3.5 (28.44-50)
Steam supply connection	DN	20
Material specification		1.4301/AISI 304
Shaft sealing		standard: sealing ring
Discharge height - tilting	mm	490
Discharge height - valve	mm	770

**Energy requirement**

Main motor n =1500/3000 min <sup>-1</sup>	kW	18.5/22
Mixing baffle drive n = 24 min <sup>-1</sup>	kW	0.75
Vacuum pump	kW	0.75
Installed energy	kW app.	26
Steam - injection	kg/h	200
Steam - double jacket	kg/h	depends on product product/batch/process
Water - vacuum pump	l/h app.	120
Water requirement for recipe	l/min app.	60
Connection for compressed air	inch	3/8"
Connection for water (recipe)	DN	20
Voltage	V/Hz	400/50